



PROMOTER: WCMC, LLC
EVENT: Bi Mart Willamette Country Music Festival
DATES OF EVENT: August 15, 16, 17 and 18, 2019

PUBLIC SAFETY PLAN

CONTACT: Sheriff Jason Myers – (503) 588-5094

Bi Mart Willamette Country Music Festival is a 4-day outdoor country music concert event. The event is held on private property owned by Jimmy and Kristine Gross. The location of the property is ¼ mile north of the intersection of Talbot Road S and Jorgenson Road S. The physical address is 13384 Jorgenson Road S, Jefferson, Oregon.

PRIMARY EVENT CONTACTS:

Anne Hankins, President - WCMC, LLC	541-521-2457
Don Leber VP, Marketing and Advertising– Bi Mart Corporation	541-554-7104
Tim Flowerday, Director of Operations – WCMC, LLC	541-908-0169
Taelor Dunn, Director of Event Planning – WCMC, LLC	541-517-7056
Mike Dunn, Operations Coordinator – WCMC, LLC	541-521-5034

ACCESS

ACCESS-CAMPING

NB- Ankeny Hill Exit 243>Ankeny Hill Rd.>Jefferson Hwy99E>Talbot Rd.>Camping Section D (GATE 12). camping in the following sections; **A, B, C, D** to the Festival site entering from North Bound I-5. This entrance/exit is a maintained two lane paved road that allows traffic control team to split traffic in multiple entrances as they enter the property.

NB- Ankeny Hill Exit 243>Ankeny Hill Rd.>Jefferson Hwy99E>Talbot Rd.>Jorgenson Rd.>Wintel Rd. (GATES 4/5). camping in the following sections; **Country Comfort/ADA** to the Festival site entering from North Bound I-5. This entrance/exit is a maintained two lane paved.

SB- Ankeny Hill Exit 243>Ankeny Hill Rd.>Wintel Rd. S>Jorgenson Rd.(GATES 8/10). camping in the following sections; **A, B, C, D** to the Festival site entering from South Bound I-5. This entrance/exit is a maintained two lane paved road that allows traffic control team to split traffic in multiple entrances as they enter the property.

SB- Ankeny Hill Exit 243>Ankeny Hill Rd.>Wintel Rd. S. (GATES 4/5). camping in the following sections; **Country Comfort/ADA** to the Festival site entering from South Bound I-5. This entrance/exit is a maintained two lane paved road.

ACCESS – DAILY PARKING

NB- Ankeny Hill Exit 243>Ankeny Hill Rd.>Jefferson Hwy99E>Talbot Rd.>Jorgenson Rd.> ENTRANCE/EXIT (GATE 11) FOR daily **PREMIUM/GA** parking for the Festival arriving from I-5 Northbound. 1,400ft of stacking.

NB- Ankeny Hill Exit 243>Ankeny Hill Rd.>Jefferson Hwy99E>Talbot Rd.>Jorgenson Rd.> WINTEL Rd.>ENTRANCE/EXIT (GATE 5) FOR daily **ADA** parking for the Festival arriving from I-5 Northbound.

SB- Ankeny Hill Exit 243>Ankeny Hill Rd.>Wintel Rd. S>ENTRANCE/EXIT (GATE 3) PREMIUM/GA traffic entering from South Bound I-5. 1,000ft of stacking then split Premium/General.

SB- Ankeny Hill Exit 243>Ankeny Hill Rd.>Wintel Rd. S>ENTRANCE/EXIT (GATE 5) ADA traffic entering from South Bound I-5.

ACCESS CONTROL

All traffic/vehicles entering the Festival site must have proper accreditation or passes to enter. This includes all vehicles/traffic other than that of responders (law enforcement, fire and safety).

Entrances/exits will be monitored 24 hours per day for the duration of the event by Security. All vehicles that enter the site will be directed to their appropriate parking or camping area depending upon their pass or accreditation. All law enforcement, fire and rescue vehicles will have priority use of the designated production entrance from the Ankeny Hill Road/I-5 interchange.

CAPABILITY OF AREA FIRST RESPONDERS

The festival venue will include a 40x40 foot first aid/medical tent (Emergency Medical Facilities as per ORS 433.760 and corresponding OAR 333-039-0040), signed in red letters with the word FIRST AID. The tents will be staffed with licensed Paramedics and Oregon licensed medical staff, with a list of the staff provided to the Marion County Health Department by August 1st. Staffing to be at State mandated levels with 1 physician per 10,000 people and 1 nurse per 7,500 people during daylight hours. During nighttime hours there will be 1 physician per 20,000 people and one nurse per 15,000 people. The number of people on site shall be monitored hourly by the use of RFID wristbands so that staffing can be adjusted based upon actual people on site. Equipment will include all standard first aid and emergency supplies necessary for a mass gathering. The emergency medical staff will be on-site 24 hours per day and will have two-way radio communications with event staff and security. The emergency medical staff will host at least 30 beds/cots for individuals needing medical attention or rest, or for the purposes of holding facilities for sick or injured awaiting transport.

The Paramedic team will be provided maps of the venue and camping areas to assist in their ability to respond quickly to emergencies. This team will arrive on-site with the proper personnel and equipment to provide triage as needed until rescue units can arrive. Ambulance service with a minimum of two ambulances during peak attendance hours will be contracted for the duration of the event. During the hours that attendance is incrementally over 20,000 a third ambulance will be placed on standby. A copy of the ambulance service contract will be provided to the Marion County Health Department before August 1st. A designated utility vehicle shall be available to the paramedics for response to camping areas.

Communication will be maintained at all times between festival staff, **Security Staff** and the paramedics/medical staff by radio and through the Command center. The paramedics will remain on site 24 hours a day during the duration of the festival, from 4pm Thursday of the event week through Monday 12:00 pm following the event each year.

An approved medical transport provider will provide medical transport for the event. Paramedics and responding transport will be provided with site maps indicating all camping areas so that they can respond to the appropriate camp site or area within the Festival grounds in a timely manner.

MARION COUNTY DEPUTIES

To assure the safety of the public, WCMC, LLC will be supplementing security staff by hiring Marion County Deputies staff to assist in assuring quiet times are observed, quick response to incidents requiring the intervention of law enforcement and a reassuring presence to families and attendees attending the Bi Mart Willamette Country Music Festival.

There shall be a minimum of two officers 24 hours per day, with an increase to twelve to eighteen officers during the peak hours of 5:00PM to 2:00AM, actual number dependent upon paid attendees. The role of this team shall be to create a “friendly presence” that reassures the public of their safety and deters potential problems, while assisting in the enforcement of quiet time. The Deputy team shall also assist security staff with incident response that requires action beyond the capabilities of security to assure continued public safety. It shall be the responsibility of the security staff to assure excellent communications with the Marion County Deputies. Marion County Sheriff's Office shall be notified in a timely manner by WCMC staff or security staff if they observe or are made aware of an alleged criminal incident. The contract with the Marion County Sheriff's Office for each year will be completed annually based upon review of staffing needs. Please see the attached commitment letter signed by Marion County Sheriff's Office.

SECURITY STAFFING

Venue

Fence Line – The fence line shall be patrolled by rovers with a rover stationed at each unique line of fencing. It is important to have a rover not patrolling a line that is broken by a change of direction of fencing as he/she will not have visual capability during parts of their shift allowing potential for passing of items back and forth over the fence.

Crowd Control – There will be teams of rovers within the crowd, each team responsible for a venue block not to exceed a potential participant count of 1500 people. In a venue of 30,000 this would mean 20 teams. The team concept is necessary so that one can engage while another continues observation.

Crowd control shall additionally include 6 rovers in plain clothes working the whole venue. These rovers will have the ability to communicate to the team within a designated area for quick response to incidents.

VIP area will be a welcoming space with perimeter and aisle presence only. The staff in this area will be distributed/staged in such a manner that if something occurs in one staff person's area a second staff person can quickly in-fill to provide backup.

Front of stage and catwalk will be staffed by people with a commanding presence, yet they will be expected to have a high degree of tolerance and the ability to defuse a situation without appearing overtly physically threatening or heavy handed. The numbers here depend upon the performance artist and his/her demeanor and stage presence.

Hospitality, artist tents, and meet & greet tent presence will be an unobtrusive team presence. This team will only respond to overt actions by individuals and at the request of the performance artist. They will see themselves more as ambassadors for the venue than an enforcement presence.

ENTRANCE GATES – GENERAL ADMISSION - Entrance gate positions serve as the primary line of defense against unauthorized items entering the venue. Bags and chairs will be checked and attendees wanded. During peak periods, 9 entrance lines will be staffed at the GA entrance. Security will have multiple staff wanding and checking bags in each line to assure that attendees are processed quickly with minimal delay. Water will be available to those showing need.

VIP, PREMIUM GENERAL ADMISSION AND HANDICAPPED ENTRANCE - Entrance gate positions serve as the primary line of defense against unauthorized items entering the venue. Bags and chairs will be checked and attendees wanded. During peak periods, 5 entrance lines will be staffed at the VIP, PREMIUM GENERAL ADMISSION AND HANDICAPPED entrance. Security will have multiple staff wanding and checking bags in each line to assure that attendees are processed quickly with minimal delay. Water will be available to those showing need. The handicap seating shall be easily accessible to the entrance. For those needing assistance, there will be volunteers to assist them to their seats. Shuttles are available during specific hours, which will be posted at the entrance.

VENDOR ENTRANCE - Entrance will be staffed by Security that will request inspection of questionable packages or containers and check for vendor credentials. Security will also observe the vendors for intoxication and randomly checking bags to assure compliance of the no alcohol rule for vendors. No unauthorized patrons or personnel shall be allowed through the vendor gate.

Each emergency exit is clearly marked "Emergency" signs. Each emergency exit is a swinging 10-foot fence panel that remains unlocked and maintained by Security.

Alcohol Control – While the minimum standard is 3 monitors for crowds of up to 7,500 and an additional monitor for every additional 2,500, BWCMF will place a monitor for every block of 1500 people. This will mean a staff of 18 roving alcohol monitors for a crowd of 30,000. (An approved TSL for plan to manage, to be attached as approved by OLCC annually)

Monitors will call upon crowd control rovers to assist with incidents so that there is not an interruption in the performance of the monitoring duties.

RV/Campgrounds

Individual Camp/RV Areas – Each designated camping/RV area requires a presence/monitoring and enforcement of quiet hours and no alcohol policy as is safety for all in the area. To achieve this Security will staff each designated area with a roaming team of security officers with transportation. Additionally, the Security staff serving the camp/rv areas will maintain their camp in a central location within the camp/rv areas to assure that they can fully monitor the areas. Quiet time/curfew will be enforced rigidly. This includes the movement of vehicles, loud or unruly behavior, loud music and/or unescorted or unauthorized roaming of any area after curfew. Patrons not observing the officially designated quiet time will be asked to leave the Festival grounds.

In order to respond quickly to public safety/health issues the Marion County Sheriff's Office shall be contracted to have a team as stated above, which shall include a utility vehicle. The Deputy team, which is on-site 24 hours a day, will assist security by providing enforcement each evening until quiet time is achieved. This team will also assist on-site security with public safety enforcement issues should they arise. It shall be the responsibility of security to maintain excellent communications with the Deputy team so that all issues are logged and addressed in the appropriate manner to assure the peace and safety of all attendees.

Communications

Communications are crucial to the success of the implementation of a security/public safety program that works effectively for WCMC. To assure that adequate communications are maintained there will be an on-site com center for the event.

The com center will be located in the back-stage area of the venue. The com center shall have a staff person 24 hours a day with radio link to the Deputy teams, the operations manager, and the overall Security lead, and back up batteries. The radios shall not be allowed to go dead. Each Deputy team will be provided a placard that lists all names, contacts, and cell phone numbers for all primary WCMC, LLC staff.

The com center will be staffed by a person who has the ability to respond quickly to situations and who can make sure that adjustments in staffing are made quickly to assure that no area is left unstaffed or unsupported. It shall be the further responsibility of the com center staff person to log and document all incidents, communications with Deputies, or changes in staffing. Radios in use during the festival shall have the ability to do an emergency "all-call" to all radios to one channel for emergency communications.

Daily

The health of any plan or organization is dependent upon ability to adjust to needs and changing conditions. In order to evaluate the success and implementation of this security/public safety program WCMC, LLC will meet with staff, Security leads and a representative from the Deputies team each day prior to opening of the venue. This will allow WCMC, LLC to make the adjustments necessary to assure the continued success of the plan and the safety of our attendees.

SAFETY LIGHTING

Approximately 40 light towers will be placed on the exterior of the venue property to ensure property safety and lighting to our ticket holders in the camping and parking areas. Approximately 8 light towers and (12) 1500-watt light balloons will be placed inside the gated venue to provide safety and lighting to our ticket holders inside the concert venue.

ALCOHOLIC BEVERAGES

Alcoholic beverages (beer, wine and distilled spirits) are sold and served in the enclosed concert venue Beer, Wine & Distilled Spirits area approved by the Oregon Liquor Control Commission. The beer, wine, and distilled spirits area (concert venue) will be secured using fencing. Service in the beer, wine and distilled spirits areas is mandatory "21 and Over." The licensed 3rd party concessionaire for the event will be WCMC, LLC. Licensed Security staff are responsible for checking proper identification in the beer, wine and distilled spirits areas. Event will follow control plan submitted to OLCC on all issues such as; carding of guests, identifying signs of intoxication, monitoring alcohol consumption, etc. Licensed Security as well as event staff, with their OLCC serving permits, will also monitor the entrance and exit to make sure that alcoholic beverages do not leave the designated service area and that no outside alcoholic beverages enter the designated area/venue. ***See attached venue layout for beer, wine & distilled spirits service area locations (final map to be submitted 30 days prior to event dates).**

The OLCC licensed concessionaire, (WCMC, LLC) is in control of all alcohol sales and OLCC control plan for beer and wine sales.

NO alcoholic beverages of any kind will be allowed out of the designated areas. Security Staff, upon entry into the concert venue will check all backpacks, purses and containers daily visually and with security wands that pick-up metal in beer tabs or alcohol lids. OLCC Licensee & Concessionaire: WCMC, LLC (541) 345-9263 office

Peter O'Rourke – (541) 953-7297 (Alcohol

Manager) Off-Site Coordinators:

Anne Hankins - (541) 521-2457

Tim Flowerday - (541) 908-0169

EVENT HOURS OF OPERATION

Thursday – Gates open at 3:00pm and close at 11:00pm

Friday – Gates open at 10:00am and close at 11:00pm

Saturday – Gates open at 10:00am and close at 11:00pm

Sunday – Gates open at 10:00am and close at 11:00pm

NOISE LIMITATIONS

Daily performances will be scheduled on the main concert stage beginning at approximately 11:00am, with performances on the acoustic stage beginning at 7:00am daily. The final performance of each day will end at 11:00pm. All sound checks conducted during the festival will be between the hours of 9am and 11:00am.

As per county Permit Standards, sound levels shall not exceed 55 d.b.a. at a distance greater than 1000 feet of the property boundary in which the event is held. The event property being designated by the Full Site map attached to this permit application.

ATTENDANCE AND PARKING

The EVENT will have an anticipated festival attendance of 30 thousand ticket holders daily. Per the Marion County Outdoor Assembly Code, the event will provide supervised parking, and will provide for dust mitigation in the parking area. Parking staff will be supervised by experienced traffic control supervisor, with supervisor to provide staffing and locations numbers to be approved by sheriff. For overnight campers, the event will have RV/TENT campsites of approximately 2500 available spaces on the leased properties as stated in the Assembly Plan. See attached Full Site map.

SMOKING

Smoking will be allowed in the concert venue in designated smoking areas.

If this mass gathering were granted by the Marion County Board of Commissioners, I approve of WCMC, LLC implementing the plan as described.

Signed, Marion County Sheriff (or designee)

Bi-Mart Willamette Country Music Festival (the event)

WCMC, LLC (the company)

EMERGENCY MANAGEMENT PROCEDURE

The following definitions have been agreed on with the Event Organizer:

I. UNTOWARD INCIDENTS:

An untoward incident is defined as a routine occurrence that negatively impacts the safe running of the event and does NOT require deputies to assume coordination of incident resolution. Despite effective planning there may be situations that are determined to be untoward incidents. If Willamette Country Music Concerts does not address such circumstances effectively, a more serious emergency situation may result. Resolution of such routine occurrences is an intrinsic part of the management of the event. Given their lack of predictability, appropriate contingency arrangements have been implemented to manage these situations from WCMC. WCMC may retain responsibility for coordination of the response even if Emergency Service assistance has been requested. However, the **Liaison Officer (LO)**, who is an employee of WCMC, LLC, in consultation with the **Operational Commander (OC)**, may decide that circumstances warrant further intervention. WCMC will then provide assistance to the deputies as required.

II. EMERGENCY SITUATIONS:

An emergency situation is defined as an occurrence that poses a threat of serious injury, loss of life or a breakdown in public order and does require deputies to assume the coordination of its resolution. Employees of WCMC and the contracted security must be aware of their own ability to cope and recognize the occurrence of or escalation to emergency situations. In such circumstances, responsibility for coordination of the response will pass to the Deputy and **OC**. The **LO** in consultation with the **OC** will be responsible for coordination of the response. During emergency situations it is essential that WCMC (through the **LO**) consults the **OC** and seeks advice on the most efficient deployment of the hired Security Staff. All Security and Officials will have a thorough understanding of the appropriate contingency arrangements. Additionally, it is recognized that circumstances may exist that cause a major incident to be declared.

III. COMMUNICATION:

WCMC will utilize its Public Address System for emergency announcements, as determined in conjunction with the **LO** in consultation with the **OC**. Back-up systems will be in place. In most emergency situations, the deployed resources available to the Emergency Services Teams will be sufficient to ensure effective resolution. In all situations, information flow will run through the **LO**. The **LO** will liaise with the **OC** to pass information to the Security Supervisors. Security Supervisors will remain in contact with WCMC through radio links. Radios in use during the festival shall have the ability to do an emergency “all-call” locking all radios to one channel for emergency communications. Security Supervisors have the responsibility to communicate vital information necessary to react to any incident or situation that may arise throughout the course of the festival to their security staff. Effective communication is key.

IV. IDENTIFICATION:

WCMC President: Anne Hankins
(541) 521-2457
anne@countrymusicconcerts.com

WCMC Event Coordinator Taelor Dunn
(541) 517-7056
taelor@countrymusicconcerts.com

BWCMF: Bi-Mart Willamette Country Music Festival
Anne Hankins (541) 521-2457

WCMC, LLC: WCMC, LLC
Anne Hankins (541) 521-2457

Liaison Officer (LO): John Bishop
541-661-2643
bishop@oregonsheriffs.org

Operational Commander (OC): TBD

Head of Security: Peter O'Rourke
(541) 953-7297
peterorourke@comcast.net

EMT Support & Life Flight: Cory Tuntland
(541) 206-3992
samson349@comcast.net

Operations Manager: Tim Flowerday, Event Management Consultants, LLC
(541) 908-0169

Site Operations Office: Mike Dunn
(541) 521-5034

Site Personnel Lead Person: Tim Flowerday, Event Management Consultants, LLC
(541) 908-0169

Contracted electrical distribution personnel:
Tim Flowerday, Event Management Consultants, LLC
(541) 908-0169

Bi-Mart Representative: Don Leber, Bi-Mart
(541) 554-7104
don.leber@bimart.com

V. EMERGENCY SITUATION RESPONSE PLANS:

In the event of an **untoward incident**, the WCMC **LO** will manage the response of Security Staff through normal radio links. An untoward incident will require a localized response, which should not require general broadcast. An announcement will not be made over the PA unless absolutely necessary. Determination of PA announcements will be made by the **LO**. Communication of an untoward incident will be made through security staff radios and shall be confined to incident staff in the general response area. Wide dissemination to other security staff will be made at the discretion of the **LO**. In all cases of an untoward event, efforts will be made to manage information in an attempt to prevent a general public panic.

In the event of a potential **emergency situation**, the Deputies will require the assistance of WCMC in the communication of essential information to Security Staff and members of the public. As previously stated, information flow will run through the **LO** unless otherwise stated. A flexible **Emergency Situation Response Plan** will be implemented as follows:

A. GENERAL EMERGENCY SITUATION RESPONSE PLAN:

1. Any Security Staff becoming aware of a potential **untoward incident** or **emergency situation** must provide a situation report (SITREP) to the **LO** immediately, preferably by radio. The SITREP will include (Who, What, When, Where, Why):
 - a) **Who:** Number of people involved, age if it can be determined, etc...
 - b) **What:** Type of incident (fight, drunk person, fire, etc...)
 - c) **When:** Is the situation ongoing or has it been resolved already? How long has it been ongoing?
 - d) **Where:** Location of incident (specific section, parking area, camping, etc...)
 - e) **Why:** Any and all information deemed essential to the effective management of the situation.
2. On receipt of a SITREP, WCMC (**LO**) will conduct an assessment in conjunction with the Head of the Security and **OC** to determine if the circumstances do, in fact, amount to a potential emergency situation. If assessed as such, the Emergency Situation Response Plan will be implemented and the **OC** will become the Incident Commander (**IC**). Otherwise WCMC will manage the incident as an untoward incident.
3. WCMC will halt any performances if deemed necessary after assessment. Only the WCMC President or the **LO** may halt a performance.
4. Although there are natural breaks in the performances, any unplanned stoppage could indicate a possible emergency situation and create a public panic.
5. In the event a performance stoppage is necessary, WCMC will instruct the Public Address System Controller to make the following announcement: "*COULD WE PLEASE ASK THE CROWD TO BE PATIENT. THERE WILL BE A SHORT DELAY*". Additional announcements will be directed or made by the WCMC President, the **LO** or the **OC**. No other party may direct or make an announcement on the public address system.
6. Radio traffic, unless essential, will be restricted to that between the initial caller and WCMC's **LO** and/or the **OC**. Any deviation from this protocol will be instigated by WCMC.
7. WCMC will consult with the **LO** and **OC** to determine the appropriate action plan required responding to the prevailing circumstances.

8. The Action Plan will then be relayed by radio to Deputies and Security Staff.
9. If evacuation of part or all of the Festival Site is required, Security Staff and Deputies will prevent re-entry without specific permission from WCMC. Reentry determination will be a combined decision of the WCMC President, the **LO** and the **OC**.
10. WCMC will advise Security Staff of their appropriate Post-Emergency Situation reporting procedure.

B. CROWD MANAGEMENT PLAN:

1. In the unlikely event that there is a crowd surge in any of the entertainment areas, the following steps will be taken:
2. Extra security staff will be radioed in from other parts of the site to help manage the situation. Either the **LO** or Head of Security can make this decision.
3. Security will stay in the 'pit' area below the stage to make sure barriers remain upright and to bring any distressed public into the pit area should they be immobilized against the barrier.
4. All stage areas have crowd barriers placed at a clear distance from the stages to ensure security have room to work as well as to prevent access on to stage by ticket holders
5. Security will be on the entrance to ensure correct numbers are maintained in the entertainment areas.
6. First Aid will be radioed to the area to treat anyone in need.
7. If necessary, the music will be stopped and an announcement made on stage by WCMC to ask the crowd to step back and calm down. The decision to make a public address announcement may only be made by the WCMC President or the **LO**.

C. CONTINGENCY FOR FIRE HAZARDS, BOMB THREATS, SUSPICIOUS PACKAGES / VEHICLES:

The following three issues are considered emergency situations. The Deputies will take the lead in dealing with all of these situations. The following information has been given to the Security Staff regarding these hazards, however the Security Staff will respond at the direction of the **OC** with information passed through the **LO**. Deputies should be aware of these general guidelines; however, they should act in accordance with their normal established procedures with the information that is passed through the **LO and OC** by way of a situation report.

1. Fire Hazards, On-Site:

- a) The risk of fire in the vicinity of the Event is always present, particularly in the following key locations:
 - i) Mobile catering facility areas
 - ii) Generator locations
 - iii) Camping areas (camp fires/grilling/etc...)
- b) Security Staff and Site Personnel will be deployed in high-risk areas and have access to relevant equipment. The Fire Marshall has sanctioned all equipment for use. Although properly equipped, Security Staff and Site Personnel should only tackle a fire provided it will not endanger life and only once the immediate area has been evacuated. It is essential that, even if extinguished, all fires are reported to the Fire Department Staff on-site.
- c) Where possible, site personnel will close off only a limited area of the site to avoid mass crowd migration.
- d) All public vehicle movement will be suspended on site to keep access clear for emergency vehicles.
- e) Extra Security Staff will be deployed in specific areas to ensure pedestrians do not obstruct emergency vehicle access.

2. Fire Hazards, Off-Site:

- a) With the threat of increasingly dry summer seasons, wildfire threats must be considered as a part of the Event Emergency Response Plan. Therefore, the **OC** and **Fire Marshall** will include in their communication plans a way to monitor wildfire events being reported/responded to by the Bureau of Land Management or the US Forest Service.
- b) In the event of a wildfire in the vicinity of the Event, all pertinent on-site personnel shall be notified through the festival communications system.
- c) Communication will be established with the Incident Commander of the wildfire response and requests for traffic or communications control shall be relayed to the **OC** and **LO**.
- d) Emergency response, up to and including site evacuation, at the Event shall begin and be supervised by the **OC** at such time as the **Incident Commander** feels public safety is at risk.
- e) Should the **OC** request evacuation, all Security and site Staff will be deployed under the direction of the **OC**.

3. Bomb Threats:

WCMC and the Security Staff must be aware of the potential, however negligible, of bomb threats and the ensuing actions that must be taken. Bomb threats may be received by any agency. In the event a bomb threat is received, the **LO** and **OC** must be informed immediately via a SITREP. The **OC**, with assistance of the **LO**, will be responsible for the coordination of the response to a bomb threat in accordance with agreed Marion County procedures.

4. Suspicious Packages and Vehicles/Potential Gun Use:

Even without the receipt of a specific bomb threat, Security Staff must remain vigilant as regards the possibility of the discovery of suspect packages, vehicles or the potential of unauthorized weapons on-site. Security Staff should make a cursory check of their area of responsibility when they commence patrol.

- a) If a suspicious package or vehicle is discovered, it should not be touched or moved.
- b) If a person with an unauthorized gun or weapon is identified, they should not be confronted.
- c) The **LO** should be informed as soon as possible via a SITREP. The **LO** will notify the **OC** immediately.
- d) The **OC** will be responsible for the coordination of the response. If the **OC**, following consultation with WCMC, decides that the appropriate response to an emergency situation is to activate an Action Plan that includes a partial or full evacuation, guidance pertinent to the implementation of the Action Plan is as follows:
 - i) WCMC will utilize the Public Address system to broadcast clear and concise instructions to the crowd to move in accordance with the Action Plan.
 - ii) Public co-operation should be requested and some reasoning behind the need to move explained.
 - iii) Security Staff and Deputies should actively encourage the crowd to move in accordance with the public address announcement. They must attempt to reassure and calm the crowd. In the event of a failure of the public address system, Security Staff and Deputies will communicate information using portable loudhailers or megaphones.

Special NOTE: radios and mobile phones should not be used within 25 meters of suspicious packages or vehicles to prevent accidental activation.

- iv) Should the Action Plan be in response to a person with a gun, a public announcement will take place in a quiet manner so as not to alert suspect of discovery. Within the immediate danger perimeter Deputies and Security Staff will quietly and calmly move people to a safe location while containing the suspect. The Deputies will take appropriate action in accordance with Marion County procedures.
- v) Notes will be taken by key personnel during the evacuation to enable a detailed post-event debrief. (See Evacuation Plan)

D. STAGE EMERGENCY PLAN STEPS FOR WEATHER EVENTS:

1. WCMC, Head of Security, the LO, and a designated representative from the Deputy's staff will meet each morning. A part of that meeting will include a review the current weather forecast. Should the forecast warn of a potential weather event, the weather will be monitored hourly and the following steps taken:
 - I. **WHEN WIND SPEEDS ARE EXPECTED TO EXCEED 20 MPH:**
 - a. A TEAM OF QUALIFIED PERSONNEL SHALL BE PUT ON ALERT. ALL NECESSARY PERSONNEL SHALL BE IN PLACE AND PUT ON STANDBY.
 - II. **WHEN WIND SPEEDS ARE EXPECTED TO EXCEED 30 MPH:**
 - a. ALL PERSONNEL SHALL BE EVACUATED FROM THE ROOF GRID, SPOT TOWERS OR OTHER ELEVATED POSITIONS WITHIN TEMPORARY STRUCTURES LOCATED ON THE SITE.
 - b. ALL VIDEO WALLS AND LARGE SPEAKER CLUSTERS SHALL BE LOWERED TO THE GROUND AND SECURED.
 - c. LOWERING OF SCRIM OR EQUIPMENT SHALL BE DONE FROM THE GROUND BY MEANS OF REMOTELY ACTIVATED EQUIPMENT SUCH AS MOTORS OR MECHANICAL RELEASES.
 - III. **WHEN WIND SPEEDS ARE EXPECTED TO EXCEED 40 MPH:**
 - a. ALL SCRIM SHALL BE REMOVED FROM THE SYSTEM.
 - b. ALL SHOW OPERATIONS SHALL BE SUSPENDED.
 - c. THE IMMEDIATE AREA SHALL BE EVACUATED OF ALL PATRONS AND NON-ESSENTIAL PERSONNEL.
 - IV. **AT WINDS SPEEDS IN EXCESS OF 50 MPH:**
 - a. ALL PERSONNEL INCLUDING STAGEHANDS, STAGE MANAGERS AND RIGGERS SHALL EVACUATE THE STAGE AREA.
2. If sustained wind speed or wind gusts reach 50 mph, all personnel, performers, technicians, and guests must clear the stage and roof area. A safety perimeter of 100 yards will be established around the stage on all sides. This includes the dressing room trailers and the green room tent. The audience will be put on alert to prepare to evacuate the area as well.
 - a. WCMC will utilize the Public Address system to broadcast clear and concise instructions to the crowd to move in accordance with the Action Plan.
 - b. Public co-operation should be requested and some reasoning behind the need to move explained.
 - c. Security Staff and Deputies should actively encourage the crowd to move in accordance with the public address announcement. They must attempt to reassure and calm the crowd. In the event of a failure of the public address system, Security Staff and Deputies will communicate information using portable loudhailers or megaphones.
3. The decision to lower the roof will be made by one of the Brown United Stage Company designated persons and he/she will make the decision along with WCMC. If it is determined the audience must be cleared from the area, the Site Personnel, Security and Deputy Staff will perform this task as per the Evacuation Plan.
4. Lightning - Brown United Stage Company shall monitor lightning strikes using Weather Ops software. The festival has adopted a minimum safe strike radius of 10 miles (the National Event Safety Alliance recommended radius is 8 miles). Should strikes occur within a ten-mile radius, the Brown United's

Lead Person in consultation with a meteorologist, shall notify the CXMF Operations Manager who shall notify the Incident Commander and the following actions will take place as necessary:

- a. Performance, if taking place, shall be paused and all personnel on stage shall leave the stage.
- b. The public, using a prepared message will be notified of lighting danger and shall be encouraged to seek safety inside buildings and safe places (this can include busses and vehicles on site), note that tents are not a safe inside location.
- c. All personnel operating equipment shall stop said operation and seek safety inside.
- d. Continued monitoring of the threat by the Brown United Stage Company lead in conjunction with the meteorologist shall determine if the threat has passed.

E. EVACUATION PLAN FOR BWCMF

- 1) In the event of an evacuation level emergency (extreme weather, wildfire, or high level bomb/public safety event) the decision to evacuate will be made jointly or singly (based upon which of these people are on the festival grounds and responsive to the situation, although all must be given notice by phone or text immediately even if not responded to) by the WCMC President, Vice President or the Festival Operations Coordinator in consultation with the OC, designated United Brown staging supervisor and emergency responders. Assessment and decision must be made in a timely manner to assure public safety.
- 2) In the event of an emergency, all security and site crew (both on and off duty) will report to the Operations Manager at the Site Operations Office. The Security Team will:
 - a) Ensure that each specified area has been cleared
 - b) The public (guests and fans) are moving off the main site
 - c) Performance artists, crew and staff are moving off the main site
 - d) Maintain clear route access for emergency vehicles, including police, fire and ambulance
 - e) Form a line, directing the public in the correct direction, reminding them to be calm
 - f) Provide information to the public as it becomes available
- 3) The public will be asked to calmly make their way off the main concert venue grounds and toward the GA parking field or area designated by the OC.
- 4) No vehicle movement is authorized for any reason. No one will be allowed to vacate the festival premises in a vehicle until the all-clear has been given by the OC.
- 5) The Public will be allowed to wait in the GA parking field and may utilize their vehicles for shelter in the event of severe weather, if not directed elsewhere by the OC.
- 6) In the event of severe injury:
 - a) The onsite First Aid Team will be called upon to deal with the injured person(s).
 - b) The ambulance service will be contacted immediately.
 - c) The person(s) will be stabilized before being moved if there is an immediate threat to their safety and to that of the First Aid team.
 - d) Only the authorized First Aid Team is authorized to make medical decisions on treatment and/or movement of an injured person.

- 7) If time allows, the following people will ensure all the electrical equipment has been shut down:
 - a) Site Personnel Lead Person
 - b) Contracted electrical distribution personnel

However, the safety of all crew must be taken into account at all times. In the event of a fire, no one will be allowed to re-enter the area until the all-clear has been given by the fire department.

- 8) Once the situation is under control, the OC in conjunction with the LO and the WCMC President will determine if the event can continue or if an entire evacuation will be necessary.
 - a) If the event is stopped altogether and an entire evacuation is deemed necessary, site personnel will begin the process of evacuating the event site, under the supervision of the OC. Site personnel, in conjunction with security staff and designated deputy officials will begin the process of traffic management to facilitate evacuation of the site.
 - b) If an emergency situation happens during the night, Deputy Officials on site will determine if evacuation would be more suitable during daylight hours, keeping in mind that many site workers will not be present during the overnight hours.
 - c) Each field will be cleared one at a time, starting with the main GA parking field. Exit will follow the established traffic control plan for the festival (attached).
- 9) A de-brief will be conducted after the event with the deputy and relevant authorities and will include all designated WCMC staff deemed necessary by the President or Operations Manager. Bi-Mart representatives are invited to participate in all after action de-briefs.
- 10) WCMC designated personnel will provide press releases as necessary and schedule interviews when convenient to the designated staff. No press will be allowed on the premises during the evacuation process.
- 11) All situations, both emergency and non-emergency, require notification of the Bi-Mart representative listed above in paragraph IV of this document. Although notification of said representatives is a requirement, press releases or other communications to external media are restricted to designated WCMC personnel.

Emergency Evacuation

In the event of an EMERGENCY EVACUATION, the Country Music Festival will manage the response in conjunction with local Sheriffs personnel. Only the festival Manager LO in conjunction with the Sheriffs commander, Fire Officials or other emergency responders are authorized to order an emergency evacuation.

The festivals security manager LO will notify security staff of the evacuation and level. The festival will then use a general broadcast when appropriate. Exit instructions will be displayed on multiple video message signs and jumbo trons throughout the venue. Security and Staff will be giving verbal instructions to patrons on the emergency and response. Directing patrons to the lighted emergency exits throughout the venue.

Code Yellow

This is a non-emergency evacuation. The Country Music festival will advise patrons that they need to exit the venue through the back exits of the festival. Reminding patrons to calmly exit. That this is a none emergency. Explaining the reason for the exit and that patrons need to exit into the festival parking lots and wait until further notice. Security Staff, Law Enforcement and Country Music Festival staff will assist in moving patrons calmly to designated exits and areas outside the venue. Security staff working in the back of the entertainment venue will move patrons seated in General seating and PGA to the back exits first.

Security working in the VIP seating area, will exit patrons when they can exit into the General and PGA seating area and calmly exit through the back gates.

Security staff will remain in the parking lot with patrons to maintain a calm presence and maintaining communication with Festival and Law Enforcement staff. Patrons will be informed of the situation to either return into the venue or leave the venue area.

Code Red

This is an emergency evacuation. The Country Music festival will notify security and Law Enforcement of the code red emergency first. Designated staff will immediately open emergency exits. Emergency exits will be clearly marked and lite. The festival through the festival PA will then advise patrons that they need to exit the venue through the nearest designated exit. Notification will be made over speakers and through the video screens. Security staff in the General and PGA seating area will move patrons to the back and side exits in an orderly manner. Instructing patrons to exit and move away from the venue.

Security working in the VIP seating area, will exit patrons through the side exits in an orderly manner. Security personnel will instruct patrons to exit and move away from the venue once they are out of the venue.

Security back stage will move patrons and staff out and away from the venue through back stage exits.

Security staff will maintain radio contact during the evacuation. In the event patrons need to be moved to different exits in the venue.

2019 Willamette Country Music Festival

Traffic Plan Overview

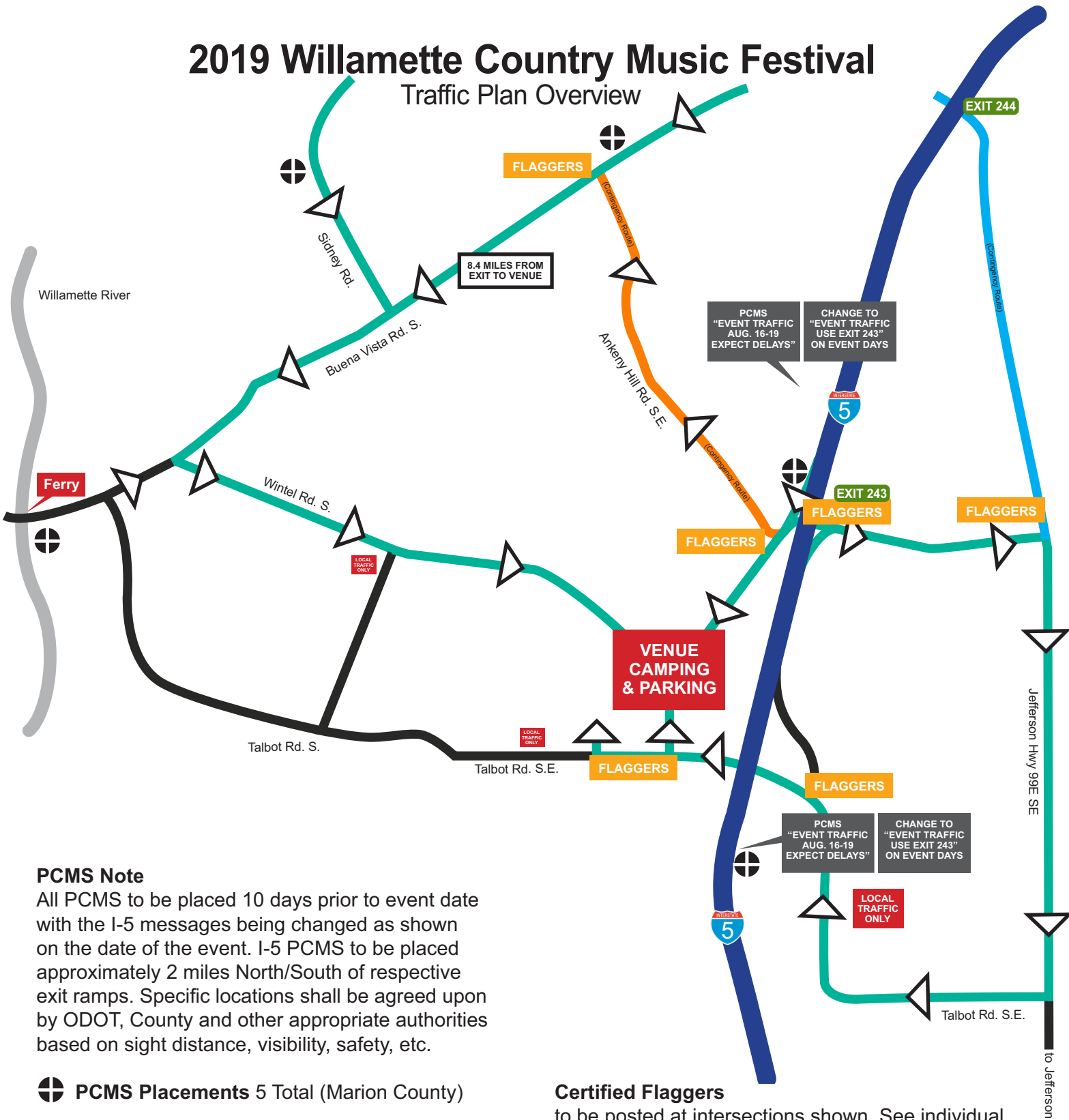

PCMS Note

All PCMS to be placed 10 days prior to event date with the I-5 messages being changed as shown on the date of the event. I-5 PCMS to be placed approximately 2 miles North/South of respective exit ramps. Specific locations shall be agreed upon by ODOT, County and other appropriate authorities based on sight distance, visibility, safety, etc.

PCMS Placements 5 Total (Marion County)

Emergency Vehicles

One lane of traffic shall always remain open at all times for emergency vehicles.

All Traffic Control

shall conform to the standards set forth in the MUTCD and the Oregon Temporary Traffic Control Handbook.

Certified Flaggers

to be posted at intersections shown. See individual sheets for TCP setup. Flaggers and security will also be used at individual parking entrances/exits based on need and actual location.

2019 Willamette Country Music Festival

Jorgenson and Talbot Intersection

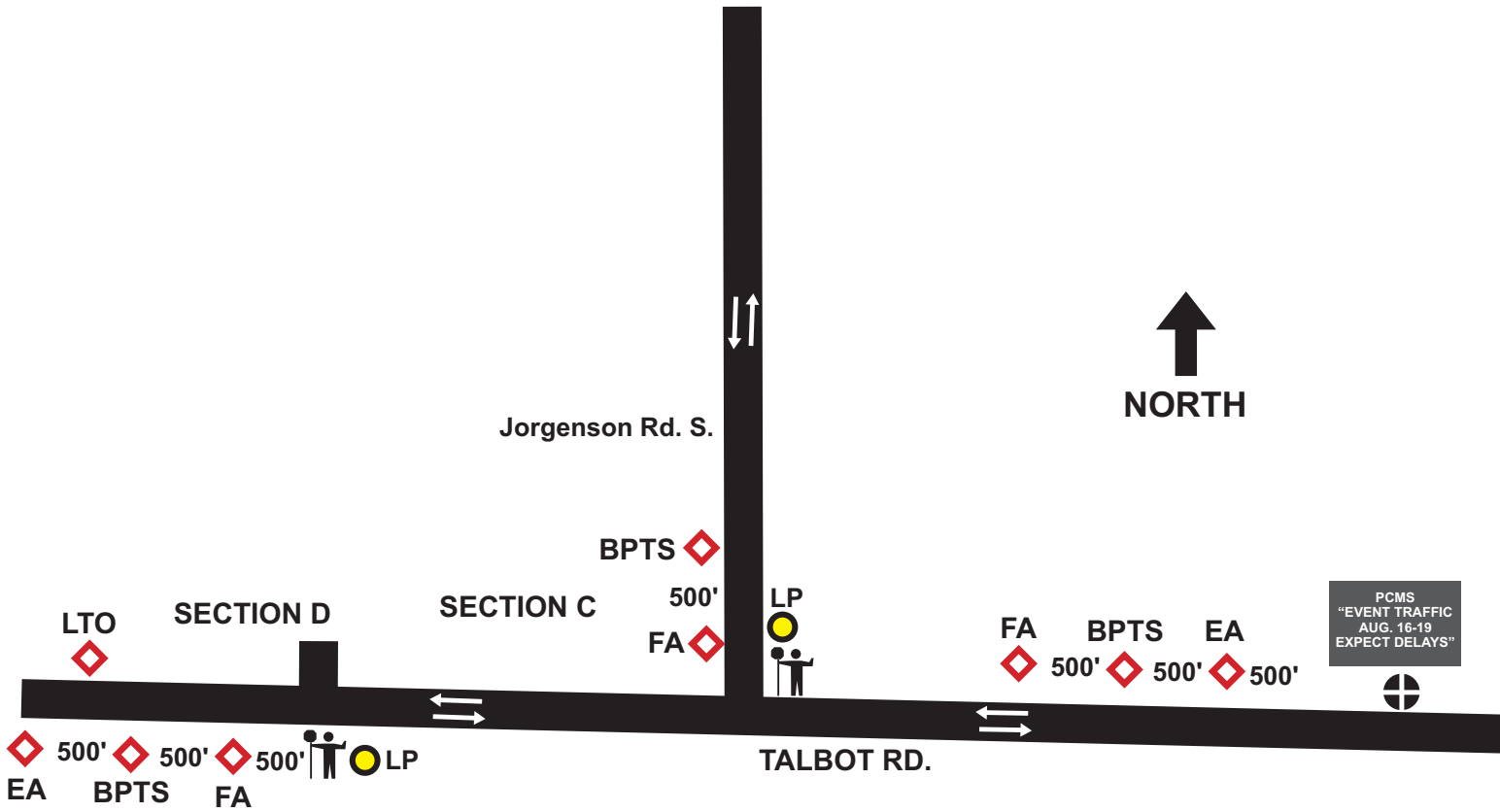

This location will be tended at all times, by one or two people– depending on the need.
 Illumination to be used only to light active flagging stations.

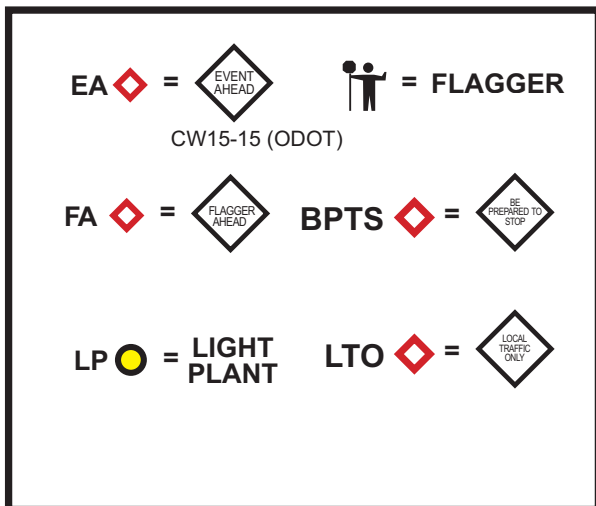

SIGN AND EQUIPMENT COUNT

Sign Spacing- 500'/ Sign Size- 36"

- Event Ahead (EA) 2
- Be Prepared to Stop (BPTS) 3
- Flagger Ahead (FA) 3
- Local Traffic Only (LTO) 1
- Light Plants 2

2019 Willamette Country Music Festival

Ankeny and Wintel Intersection

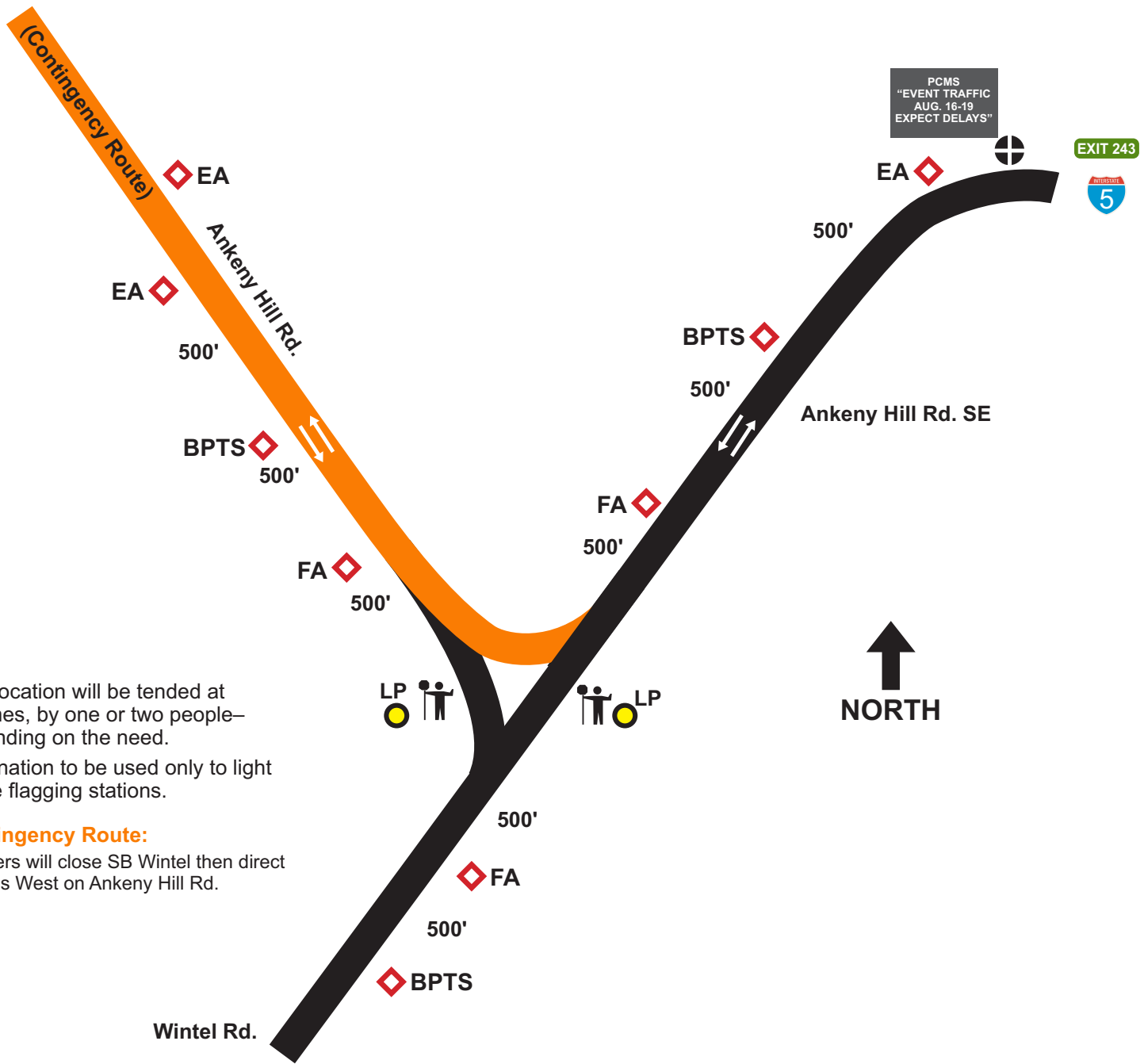

This location will be tended at all times, by one or two people—depending on the need.

Illumination to be used only to light active flagging stations.

Contingency Route:

Flaggers will close SB Wintel then direct patrons West on Ankeny Hill Rd.

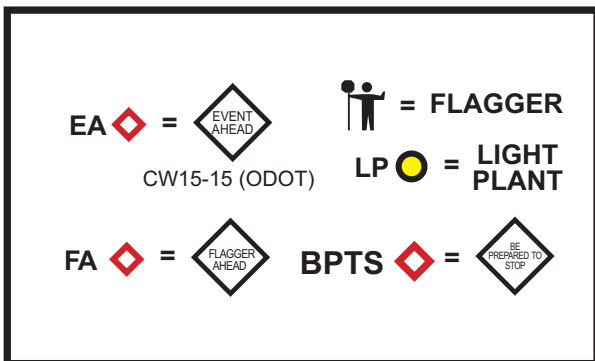

SIGN AND EQUIPMENT COUNT

Sign Spacing- 500' / Sign Size- 36"

Event Ahead (EA)	3
Be Prepared to Stop (BPTS)	3
Flagger Ahead (FA)	3
PCMS	1
Light Plants	2

2019 Willamette Country Music Festival

Buena Vista Rd. and Ankeny Hill Intersection

PCMS
"EVENT TRAFFIC
AUG. 16-19
EXPECT DELAYS"

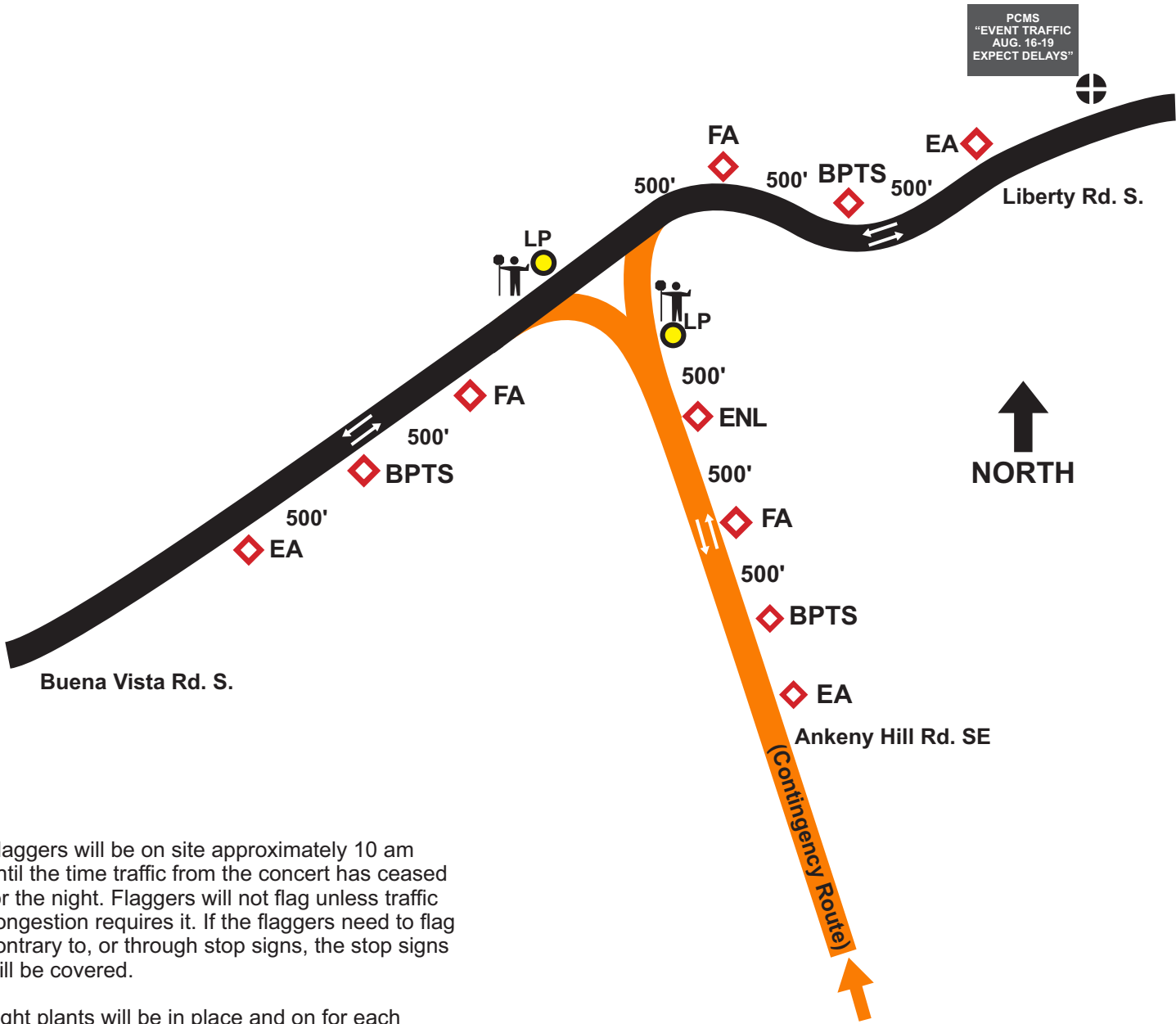

Flaggers will be on site approximately 10 am until the time traffic from the concert has ceased for the night. Flaggers will not flag unless traffic congestion requires it. If the flaggers need to flag contrary to, or through stop signs, the stop signs will be covered.

Light plants will be in place and on for each flagger. All times will be reviewed daily and changed accordingly.

EA			= FLAGGER
			CW15-15 (ODOT)
FA		BPTS	
	W20-7a		W3-4
LP		ENL	
	LIGHT PLANT		EVENT NEXT LEFT

SIGN AND EQUIPMENT COUNT
Sign Spacing- 500'/ Sign Size- 36"

Event Ahead (EA)	3	
Be Prepared to Stop (BPTS)		3
Flagger Ahead (FA)		3
Event Next Left (ENL)		1
PCMS		1
Light Plants	2	

2019 Willamette Country Music Festival

Buena Vista Rd. and Wintel Intersection

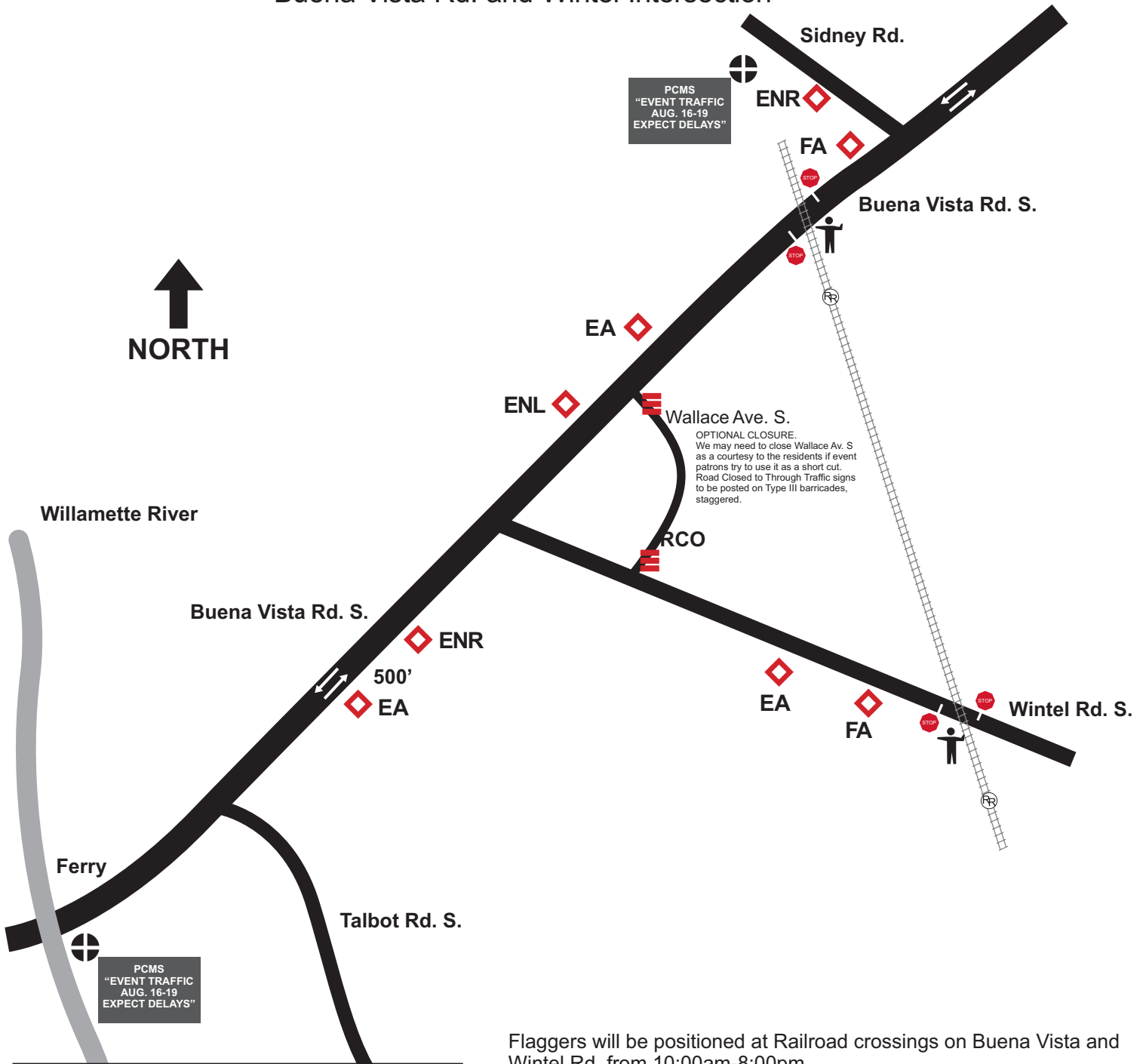

PCMS
"EVENT TRAFFIC
AUG. 16-19
EXPECT DELAYS"

PCMS
"EVENT TRAFFIC
AUG. 16-19
EXPECT DELAYS"

OPTIONAL CLOSURE.
We may need to close Wallace Av. S
as a courtesy to the residents if event
patrons try to use it as a short cut.
Road Closed to Through Traffic signs
to be posted on Type III barricades,
staggered.

EA		=		EVENT AHEAD
				CW15-15 (ODOT)
FA		=		FLAGGER AHEAD
				W20-7a
ENR		=		EVENT NEXT RIGHT
ENL		=		EVENT NEXT LEFT
	RAILROAD			

Flaggers will be positioned at Railroad crossings on Buena Vista and Wintel Rd. from 10:00am-8:00pm.

SIGN AND EQUIPMENT COUNT
Sign Spacing- 500'/ Sign Size- 36"

Event Ahead (EA)	3
Flagger Ahead (FA)	2
Event Next Right (ENR)	2
Event Next Left (ENL)	1
Road Closed Local Traffic Only (RCO) Type III Barricade	2
PCMS	2

2019 Willamette Country Music Festival

I-5 and Ankeny Hill Rd. Exit 243

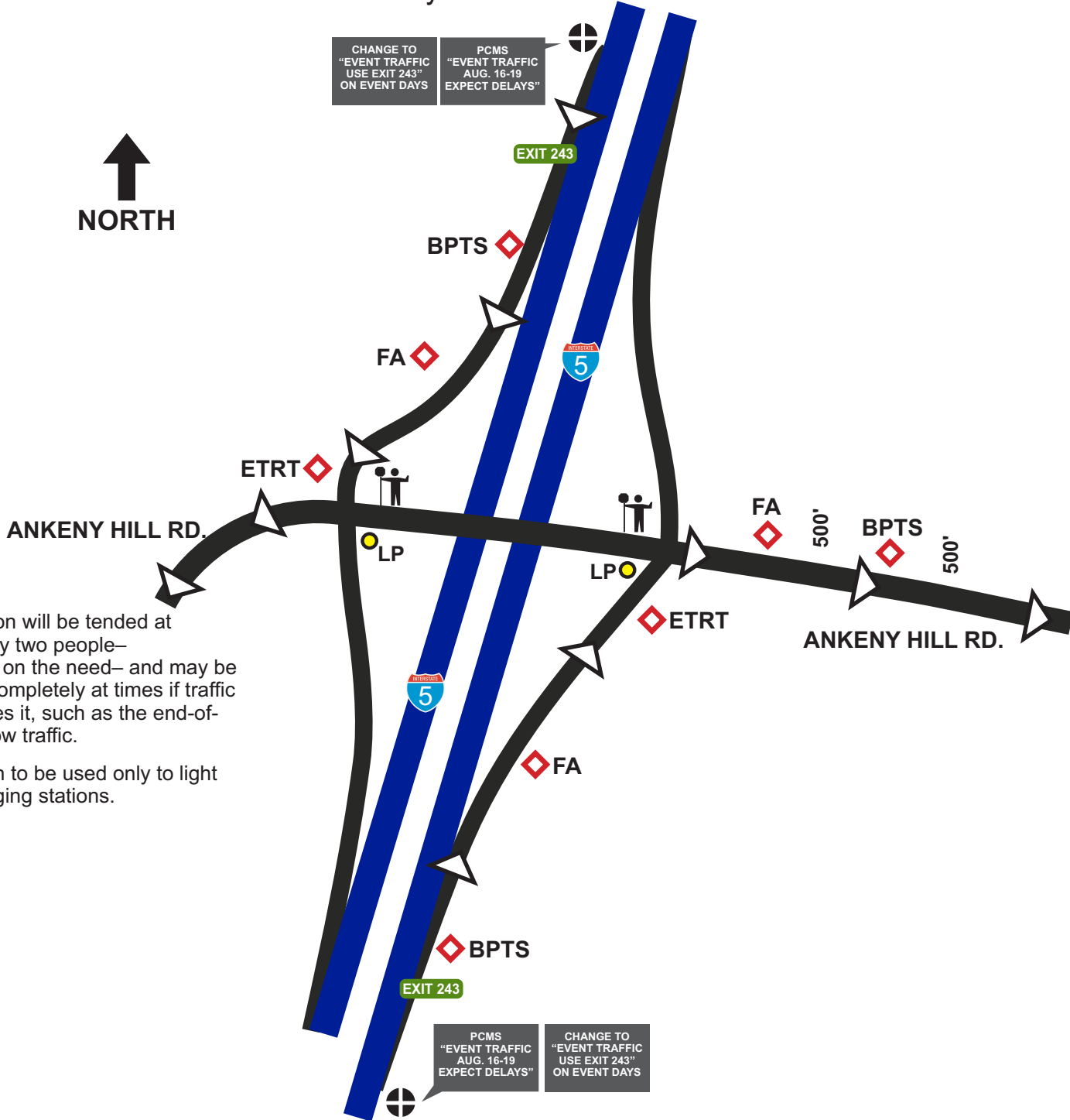

This location will be tended at all times, by two people— depending on the need— and may be removed completely at times if traffic flow dictates it, such as the end-of-night outflow traffic.

Illumination to be used only to light active flagging stations.

FA				= FLAGGER
			LP	= LIGHT PLANT
ETRT			BPTS	=

SIGN AND EQUIPMENT COUNT

Sign Spacing- 500' / Sign Size- 36"

Be Prepared to Stop (BPTS)	3
Flagger Ahead (FA)	3
PCMS	2
Light Plants	2

2019 Willamette Country Music Festival

Ankeny Hill Rd. SE & Jefferson Hwy 99E SE Intersection

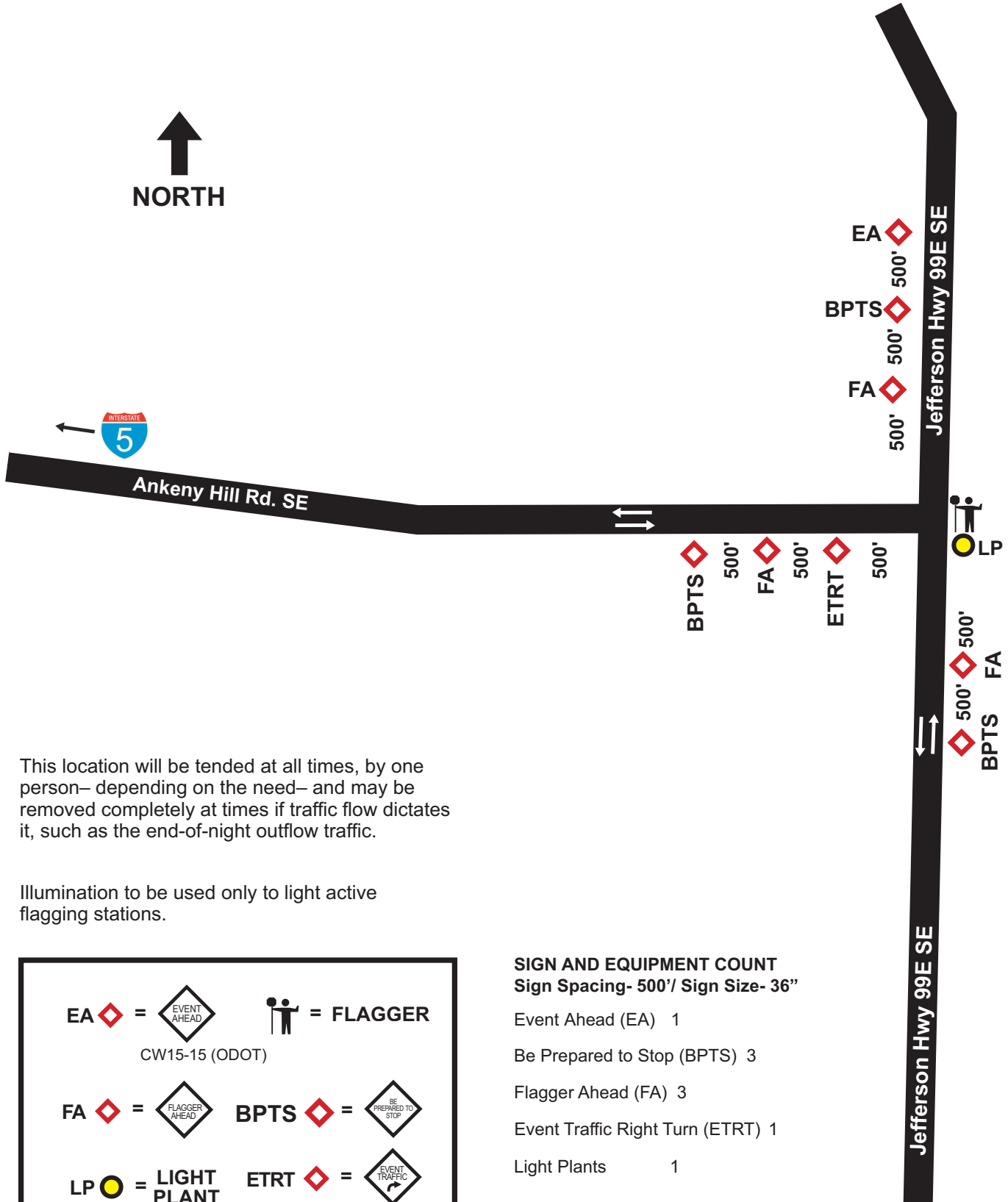

This location will be tended at all times, by one person— depending on the need— and may be removed completely at times if traffic flow dictates it, such as the end-of-night outflow traffic.

Illumination to be used only to light active flagging stations.

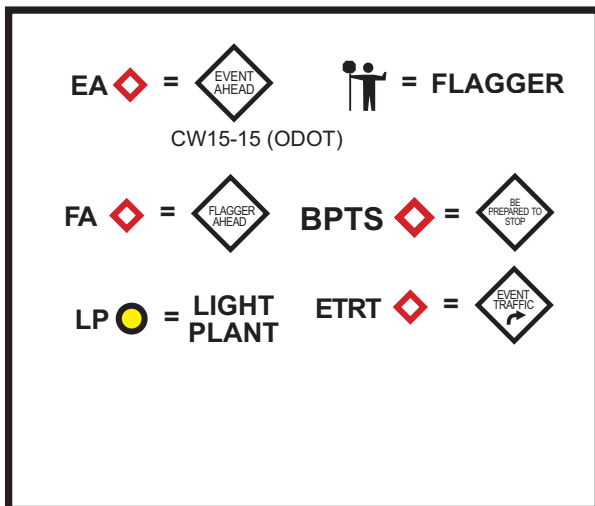

SIGN AND EQUIPMENT COUNT Sign Spacing- 500' / Sign Size- 36"

- Event Ahead (EA) 1
- Be Prepared to Stop (BPTS) 3
- Flagger Ahead (FA) 3
- Event Traffic Right Turn (ETRT) 1
- Light Plants 1

2019 Willamette Country Music Festival

I-5 and Talbot Rd. Exit 242

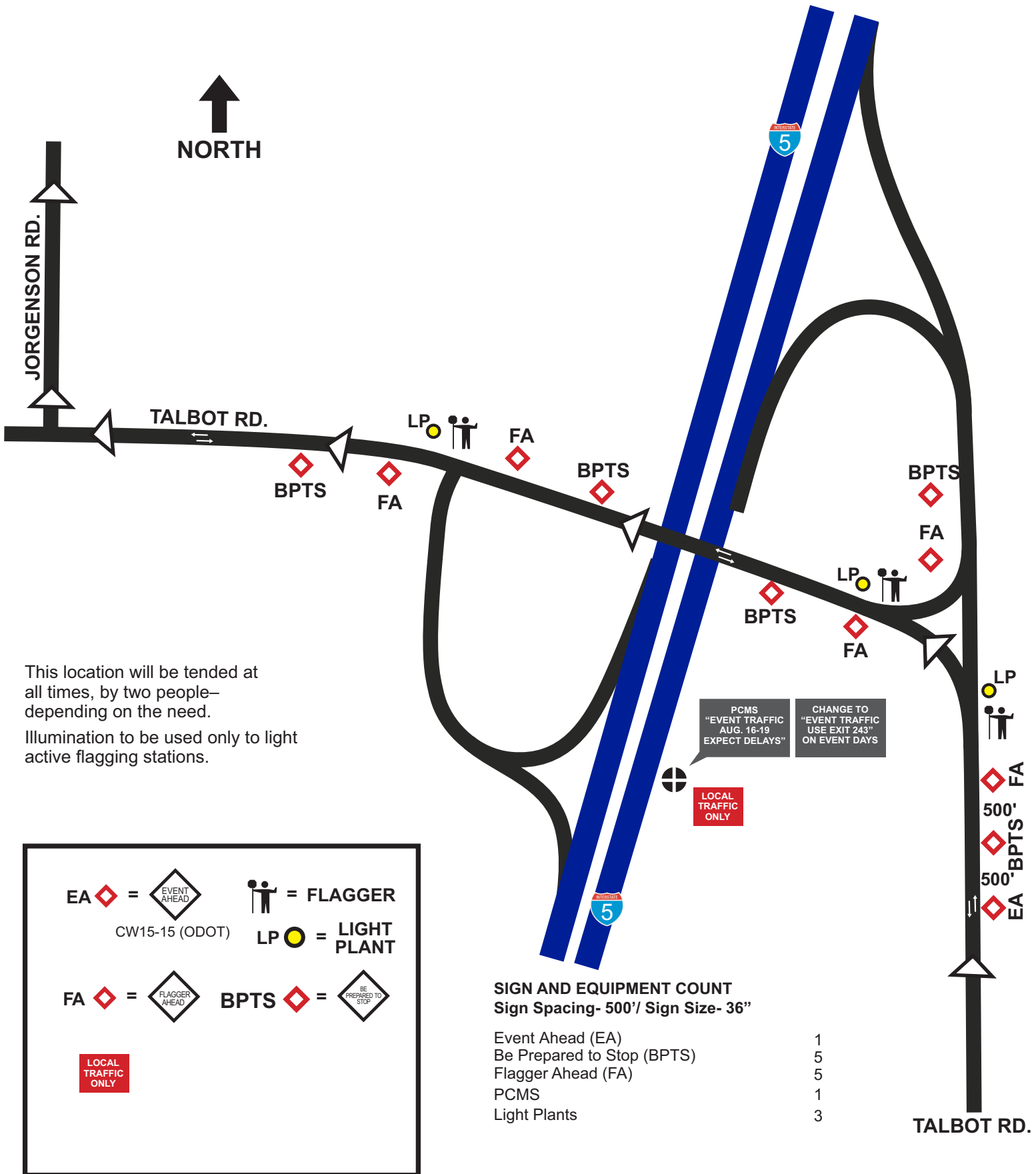

2019 Willamette Country Music Festival

Northbound Primary Route (Exit 243)

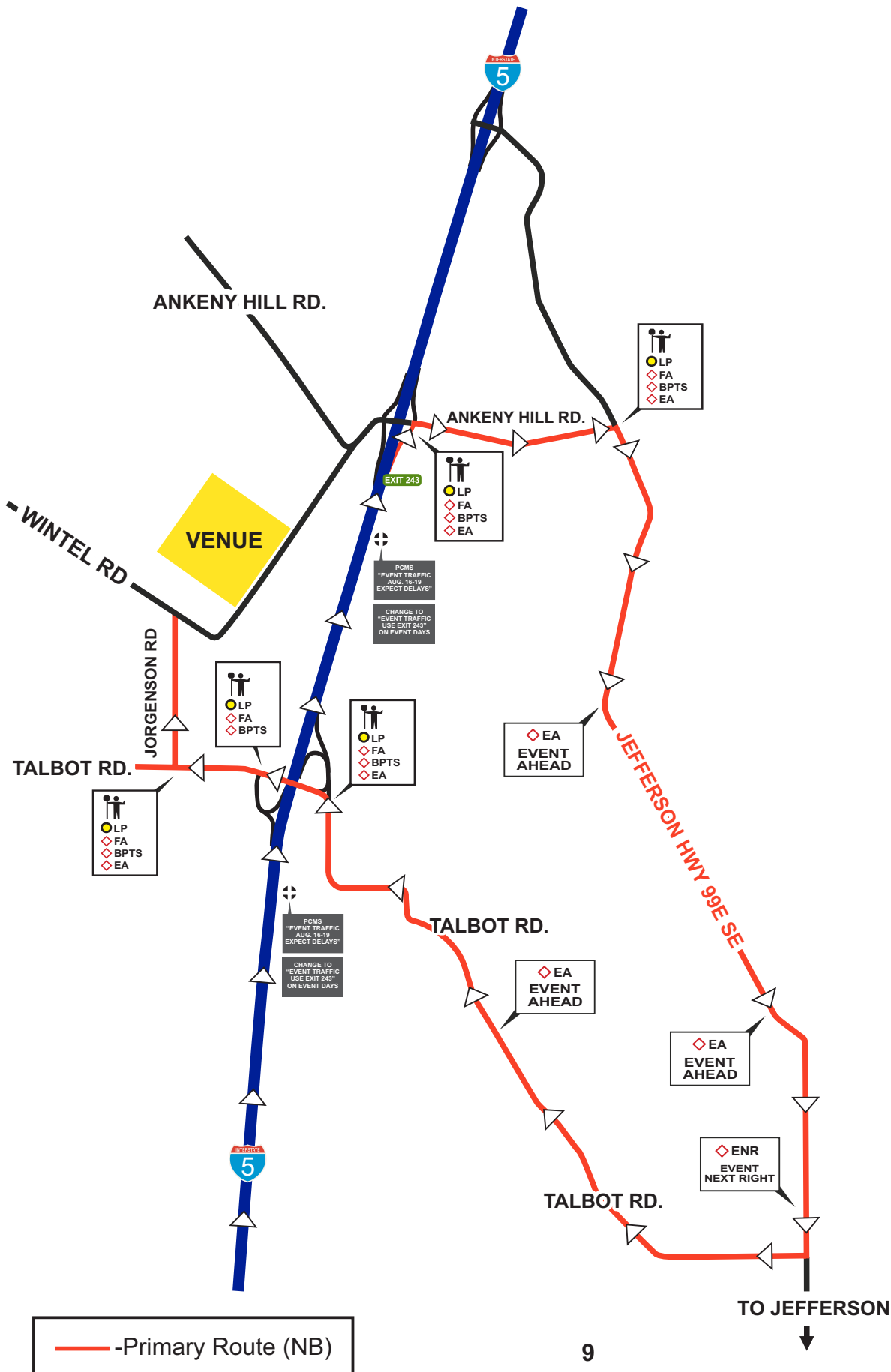

2019 Willamette Country Music Festival

Northbound Contingency Route (Exit 244)

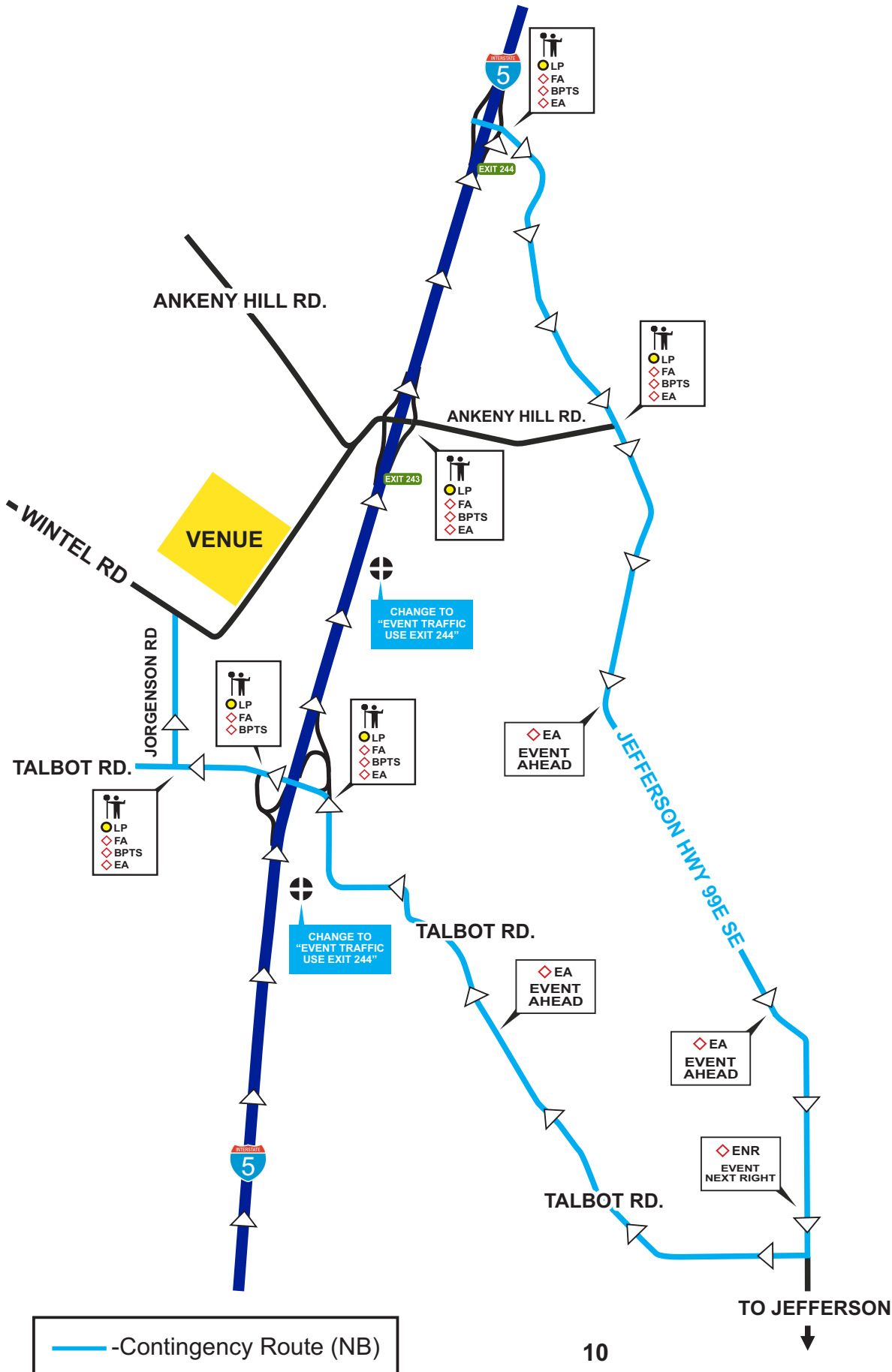

2019 Willamette Country Music Festival

Southbound Primary Route (Exit 243)

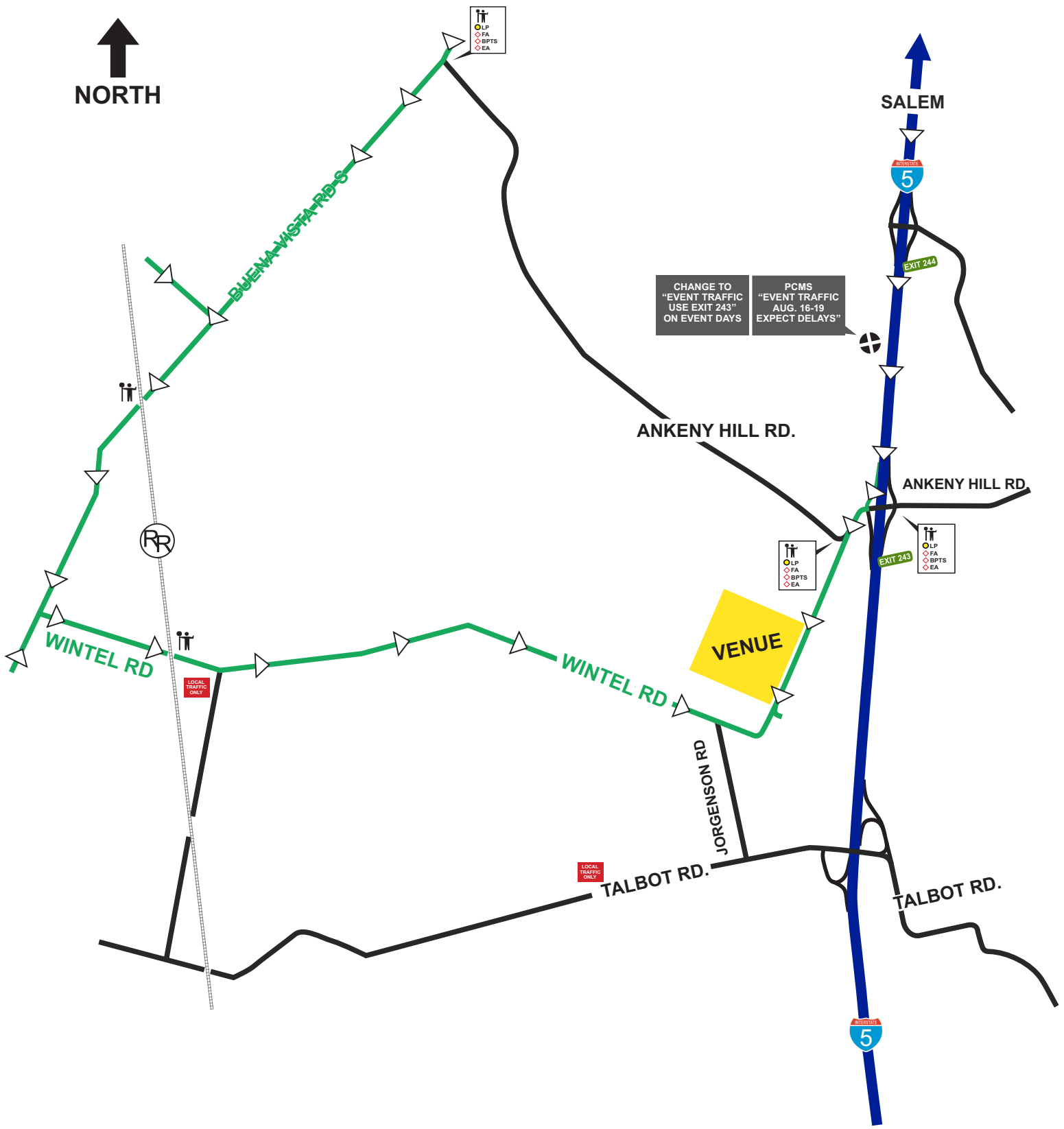

— -Primary Route (SB)

2019 Willamette Country Music Festival

Southbound Contingency Route (Ankeny Hill Rd.)

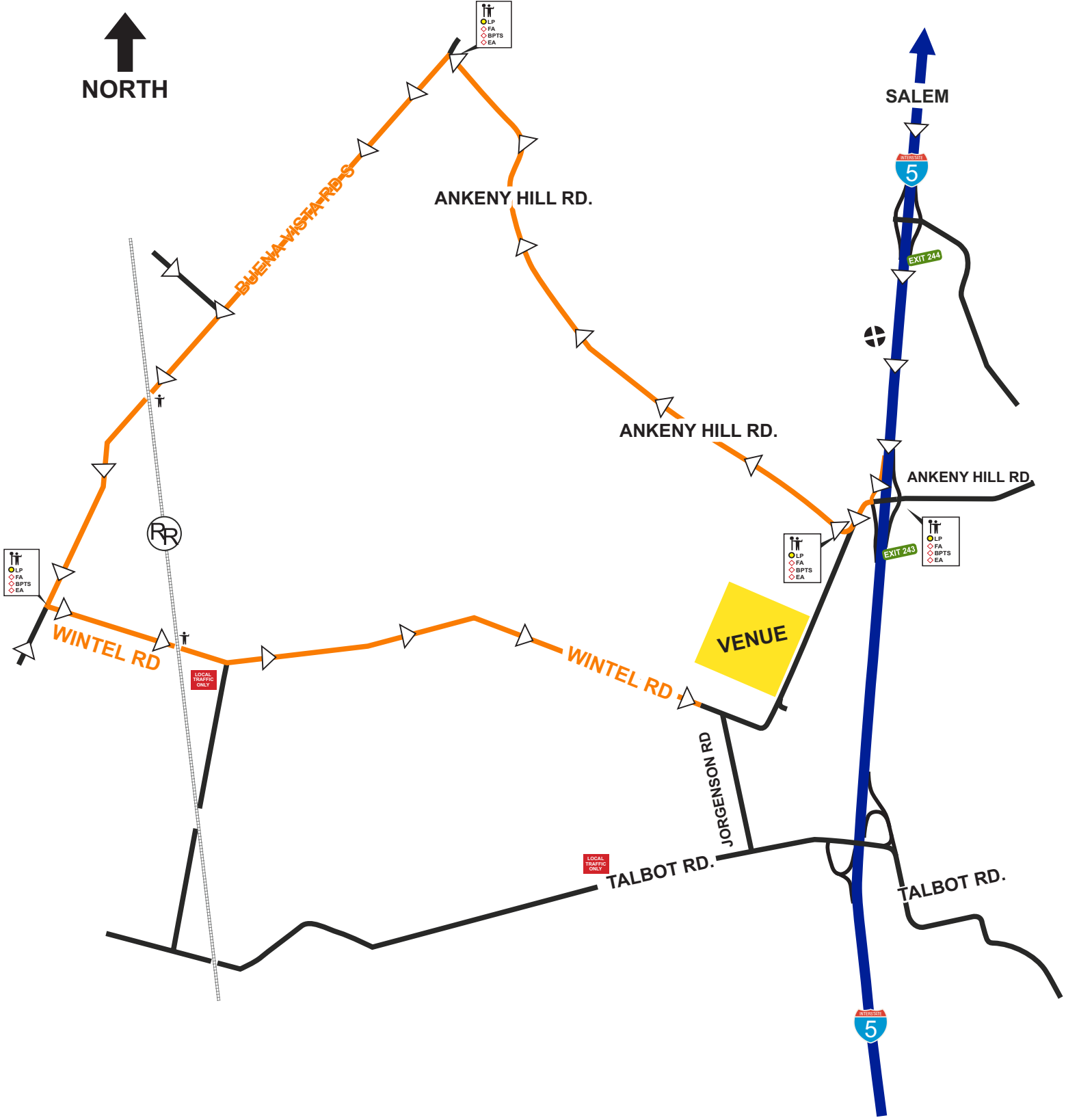

—Contingency Route (SB)

2019 Willamette Country Music Festival

Outbound Traffic

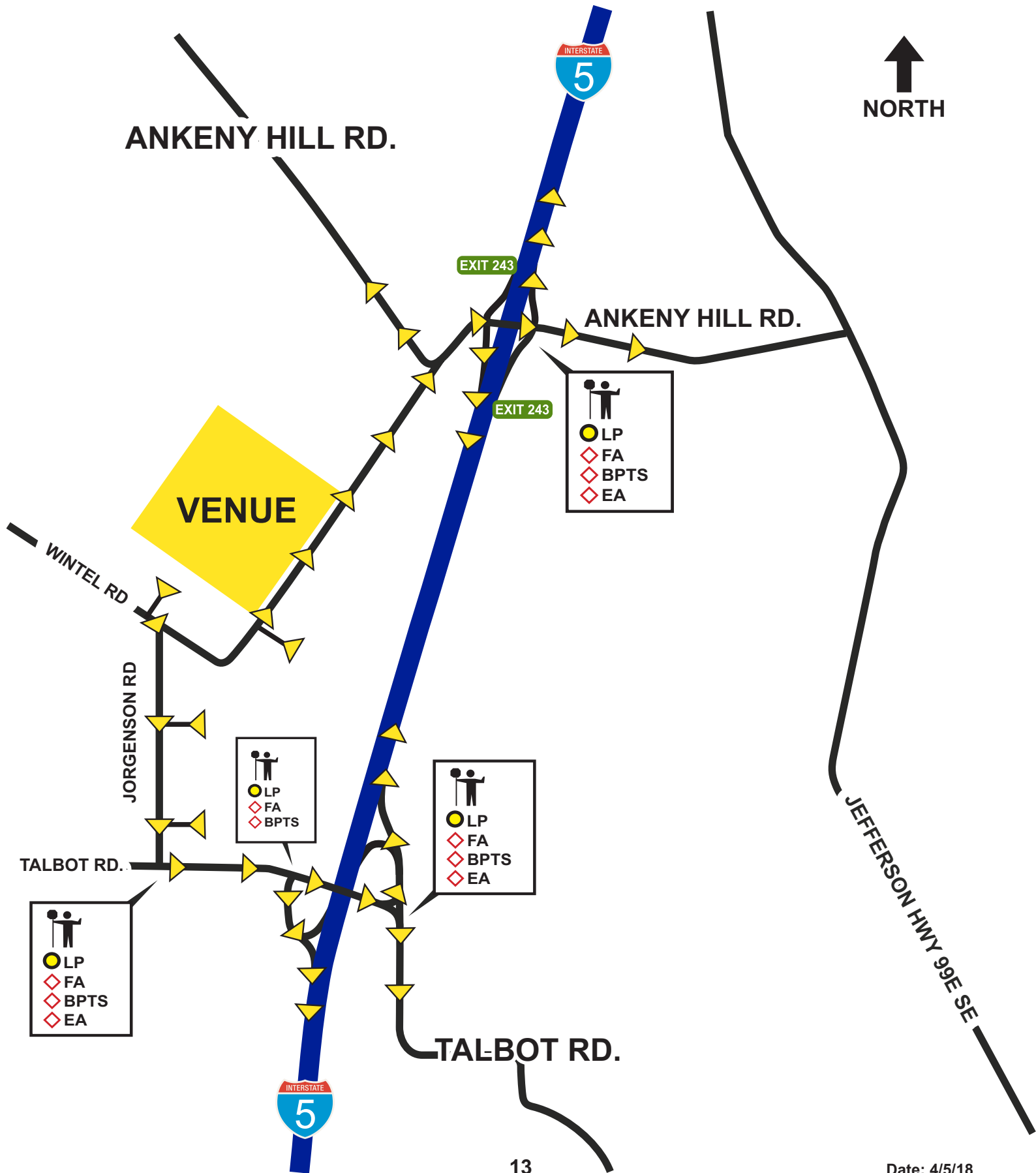

2019 Willamette Country Music Festival

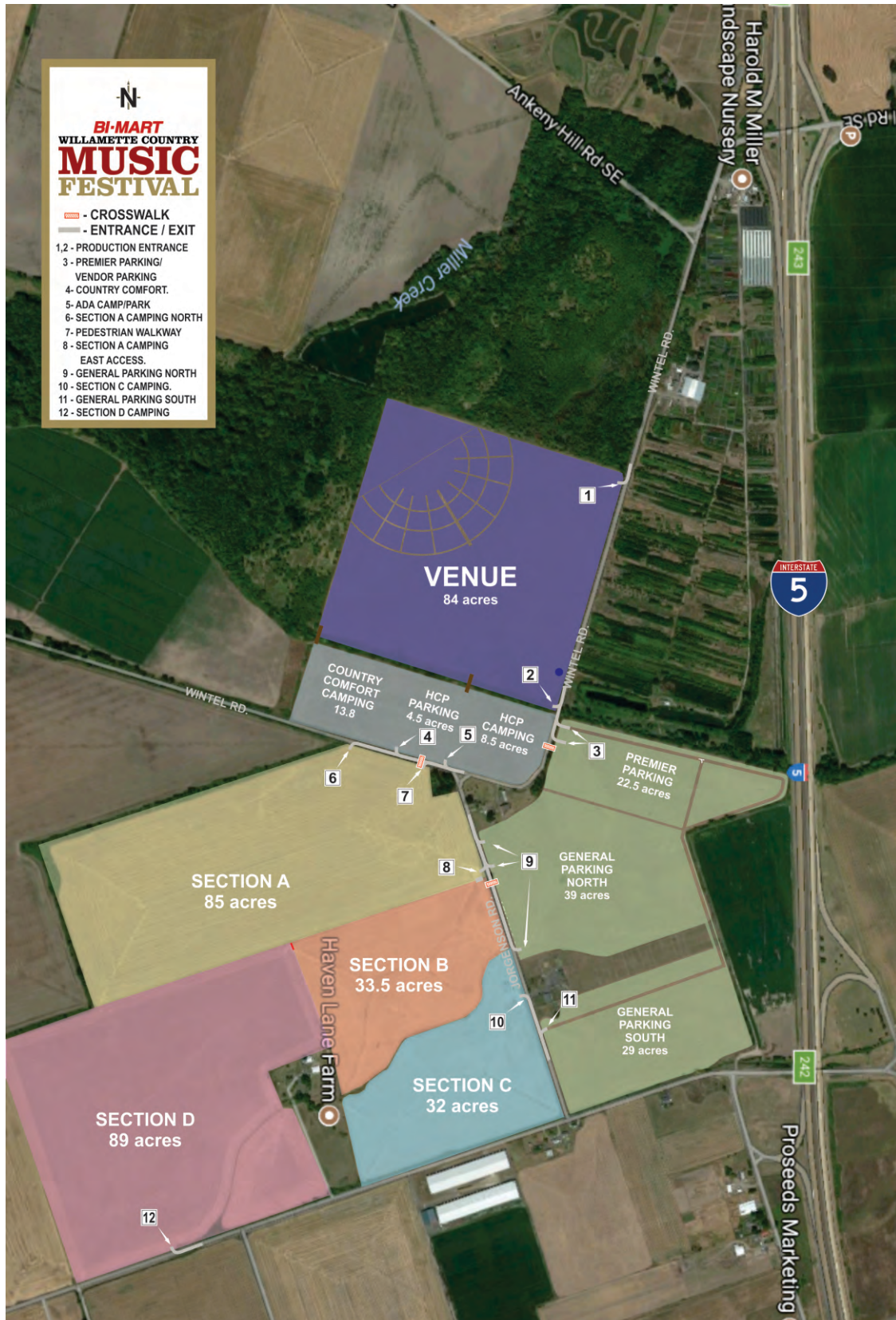

“Flaggers will be located at all driveways to the parking lots and camping sections. Flaggers and Light Plants will be located at all pedestrian crossings of the county roads”